

The P-400 Gibraltar Proximity Reader is a member of the *Pyramid Series* Proximity line of OEM proximity readers, cards and tags for access control from Farpointe Data. Making use of proven digital radio frequency identification (RFID) technology, it is constructed of stainless steel and Fiber-Tex® (UL752 listed for bulletproof integrity) providing the very highest levels of vandal resistance. Additionally the P-400 features the option of HID proximity compatibility (model P-400-H) allowing it to read both HID and Pyramid Series cards and tags.

The single-piece P-400 delivers non-contact read ranges up to 1 inch (25 mm), and operates from 5 to 14 VDC. Physical size is a compact 5.25 x 2 x 0.75 inches (134 x 51 x 19 mm). To allow both indoor and outdoor operation the electronics are secured in tamper-resistant epoxy potting. Mounting provisions include two countersunk 0.25 inch thru-holes, as well as four ¼-20 tapped holes in the back, providing the option of a tamper-proof blind mount.

The Pyramid Series line includes a comprehensive selection of proximity access cards and tags that may be used interchangeably with any of the Pyramid Series readers, including the PSC-1 Standard Light Proximity Card, the PSI-4 Image Technology Proximity Card, the PSM-2 Multi-Technology Proximity Card, and the PSK-3 Proximity Key Ring Tag.

- Proximity RFID technology.
 - » No direct physical contact between reader and card required.
- Highest level of vandal resistance.
 - » Ideal for schools, universities, and high-threat inner city environments.
- Stainless Steel and Fibertex®.
 - » Must materials when crime and vandalism are constant threats.
- Beeper standard.
 - » Provisions for both system and local control.
- Pass-Thru Wiegand and magnetic stripe outputs standard.
 - » Compatible with all standard access systems.
- Configurable via Control Cards.
 - » Local customization allows optimized reader operation.
- Optional HID compatibility.
 - » When enabled, reads both HID and Pyramid Series cards and tags.
- www.FarpointeData.com.
 - » For the latest on your INTELLIGENT proximity alternative™.



**PYRAMID SERIES
PROXIMITY**

P-400 Gibraltar Proximity Reader

Data Sheet

Pyramid Series Proximity™

Read Range ^a:	PSC-1 - Up to 1 inch (25 mm) PSI-4 - Up to 1 inch (25 mm)	PSM-2 - Up to 1 inch (25 mm) PSK-3 - Up to 1 inch (25 mm)
Size: 5.25 x 2 x 0.75 inches (134 x 51 x 19 mm)	Weight: 18 oz. (510 g)	
Input Voltage ^b: +5 to 14 VDC	Current Draw: 90 mA typical	
LED Indicator: N/A	Audio Tone: Standard	
Frequency: 125 KHz excitation	Operating Temperature: -40° C to +65° C	
Colors: Stainless Steel and Fibertex®	Metal Mounting: May be mounted directly to metal.	
Formats: Wiegand (26-bit Industry Standard and custom formats) and ABA Track II magnetic stripe (clock and data)		
Credential Compatibility: Standard - Pyramid Series Cards and Tags (PSC-1, PSI-4, PSM-2, and PSK-3) Optional ^c - HID (ProxCard II, ISOProx II, and ProxTag II) and Pyramid Series Cards and Tags		
Warranty: The P-400 carries a limited lifetime warranty against defects in materials and workmanship.		
Certifications: CSA, UL, FCC, CE, C-Tick.		

- Read range is stated in a clean RF and electrical environment using PSC-1 cards presented parallel to the reader surface with the reader operating at 12 VDC. Additionally, read range may be affected by local installation conditions.
- Use of a linear power supply is always recommended.
- To designate optional HID compatibility, add the "H" suffix to the model number (e.g. P-400-H). For further information, see the section regarding HID compatibility in the Pyramid Series Reader Product Manual.

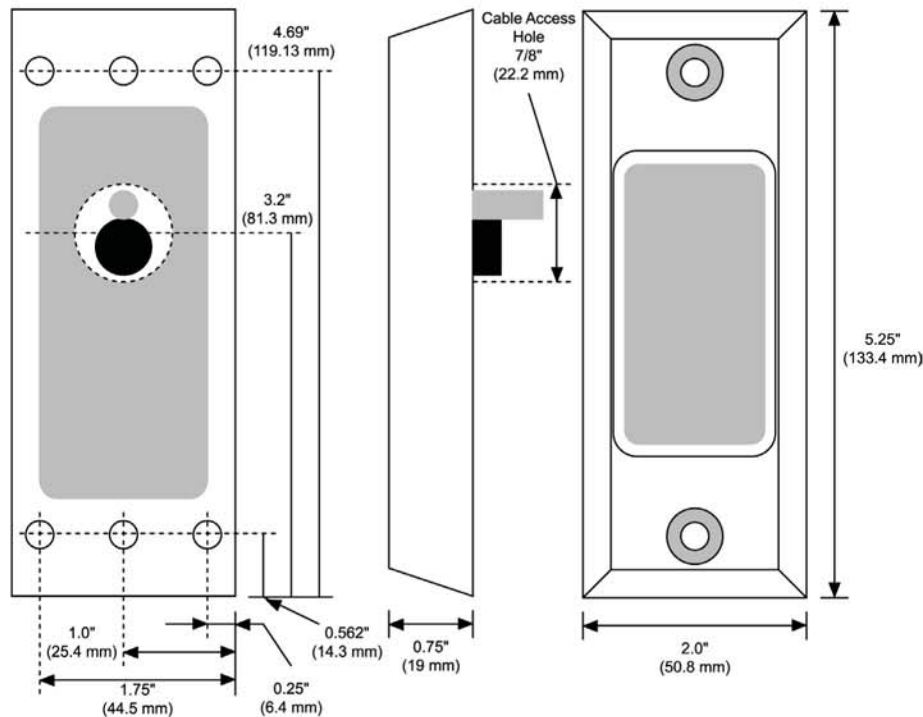

Farpointe Data reserves the right to change specifications without notice.

©2004 Farpointe Data, Inc. - All other trademarks are the property of their respective owners.

Protected by U.S. and Worldwide Patents.



TransTech Systems
 PO Box 2357 Wilsonville, OR 97070
 Phone: 888.843.3643 Fax 503.682.0166
 Email sales@ttsys.com www.ttsys.com